

1324

LEGACY SERIES™ H20
POLYMER CONCRETE/STEEL

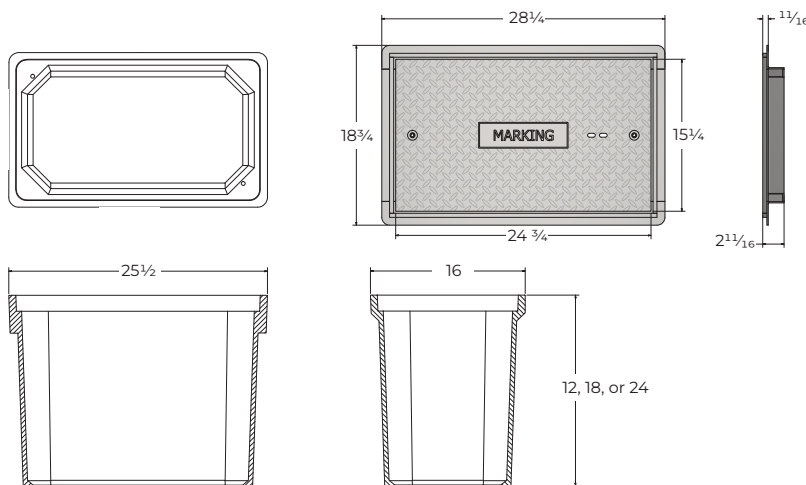

BOLT DOWN OPTIONS

- + Hex Head 
- + Penta Head 
- + Standard Thread
- + Auger Thread

PRODUCT OPTIONS AND ACCESSORIES

- + Knockouts, Mouseholes, and Conduit Entries
- + Cable Racking
- + Dividers
- + EMS Locators
- + Specialty and Security Hardware
- + Grounding and Bonding Accessories

PACKAGING AND SHIPPING

	PALLET QUANTITY
13" x 24" x 12"	20
13" x 24" x 18"	15
13" x 24" x 24"	10

PERFORMANCE



Engineered to satisfy the applicable ASTM C1802 load classification. Select products and configurations may be designed to accommodate loading conditions consistent with AASHTO H20 requirements where specified.

MARKING OPTIONS

When it comes to marking plates, **your standard is our standard.** Custom markings and artwork are a breeze to customize your enclosure. Connect with our team for more information on markings.

PRODUCT TYPE	NOMINAL SIZE	PERFORMANCE	PART NUMBER	APPROXIMATE WEIGHT
Unit	13" x 24" x 12"	H20	SP132412UTR99HS	172 lbs.
Unit	13" x 24" x 18"	H20	SP132418UTR99HS	199 lbs.
Unit	13" x 24" x 24"	H20	SP132424UTR99HS	208 lbs.

Part numbers listed in the table are for standard boxes without accessories. Unit part numbers include an installed marking plate. Units listed above have hex-head, standard thread hardware.

APC PRODUCTS MEET OR EXCEED THE FOLLOWING STANDARDS & GUIDELINES:

- + Build America, Buy America (BABA)
- + ANSI/SCTE 77 2023
- + Telcordia GR-902-CORE
- + Western Underground Committee



The materials and information in this document have been prepared by American Polymer Company for informational purposes only. American Polymer Company reserves the right to make changes or improvements to the products described in this document at anytime without notice. Revision Date: 06/2026

SS-LSH173001-0626 © American Polymer Company

